

BreadCrumb® ME4

Portable Wireless Mesh Network Node

The Rajant BreadCrumb ME4 is a rugged, wireless device that forms a mesh network when used in conjunction with other BreadCrumb systems. This portable, wireless mesh network node contains two transceivers and up to four external antenna ports. It provides Ethernet and Wi-Fi Access Point interfaces to enable data, voice, and video applications. The ME4 is reliable in extreme environmental conditions and has several mounting options.



BreadCrumb ME4 Key Features

- Rajant's patented InstaMesh® networking software, enabling the network to quickly adapt to rapidly-deployed and quickly- or constantly-moving network elements
- Multiple transceiver configurations for high levels of network reliability, redundancy and diversity, and fewer problems due to interference, congestion, and equipment outages
- Radio frequencies – 900 MHz, 2.4 GHz, 4.9 GHz, 5 GHz and others
- Two antenna-port configurations with 2x2 MIMO (multiple-input, multiple-output), substantially increasing the capacity of a transceiver
- Support for several strong cryptographic options used for data and MAC-address encryption and per-hop, per-packet authentication (list of options on page 3)
- Lightweight and portable
- Rugged and environmentally sealed enclosure
- High bandwidth for data, voice, and video applications
- Scalability to hundreds of mobile, high-bandwidth nodes
- Integrated Wi-Fi Access Point service for compatibility with millions of commercial off-the-shelf (COTS) client devices such as laptops, tablets, smart phones, IP cameras, sensors, and other IP devices
- Self-configuring operation for fast and easy deployments
- Reliable and fast off-loading to Ethernet via multiple, simultaneous bridge-mode links through the Automatic Protocol Tunneling (APT) feature
- Mesh Clustering to designate per-BreadCrumb sub-meshes that will only mesh with a user-specified series of nodes, useful applications include:
 - Enabling two BreadCrumbs to operate in a point-to-point (PTP) capacity on the same channel as other mesh nodes, eliminating the need to purchase a third-party PTP link for backhaul
 - Isolating one or more groups of BreadCrumbs to mesh with each other and not with other nodes outside the user-defined mesh cluster

Utilizing ME4 BreadCrumbs to Your Advantage

The ME4 is our mid-level BreadCrumb solution and is an ideal alternative for adding wireless infrastructure and mobile nodes into your existing network. This system can be deployed in a variety of wired and wireless platforms such as LTE, satellite, and Wi-Fi. The ME4 offers unparalleled reliability, performance, scalability, and security to support virtually any application, operating flawlessly in even the most challenging environments. While the LX5 is recommended to build your core Rajant mesh infrastructure, the ME4 is an excellent solution to expand coverage within your private wireless network.

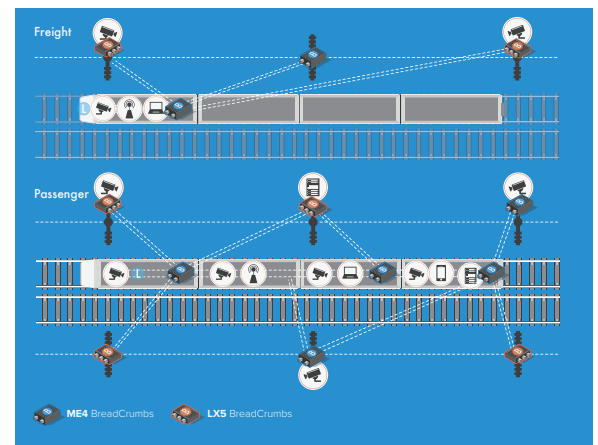

ME4 BreadCrumbs are designed to perform flawlessly in a variety of industrial environments such as Transportation and integrate seamlessly with our LX5 and JR2 models to form a complete meshing solution.

InstaMesh®

InstaMesh is the advanced, patented¹ protocol developed by Rajant that directs the continuous and instantaneous forwarding of wireless and wired connections. It enables complete network mobility, robust fault tolerance, high throughput, and low latency with very low maintenance and administrative requirements. Because InstaMesh operates at Layer 2 and does not use a root node or LAN Controller, mobility and bandwidth are maximized. No matter how you configure your network, InstaMesh networking software always determines the most efficient pathway between any two points, even when those points are in motion.

This diagram shows how your Rajant mesh network can adapt to the changes caused by the movement of Node E. New links are established in real-time keeping the network available, intact and secure.

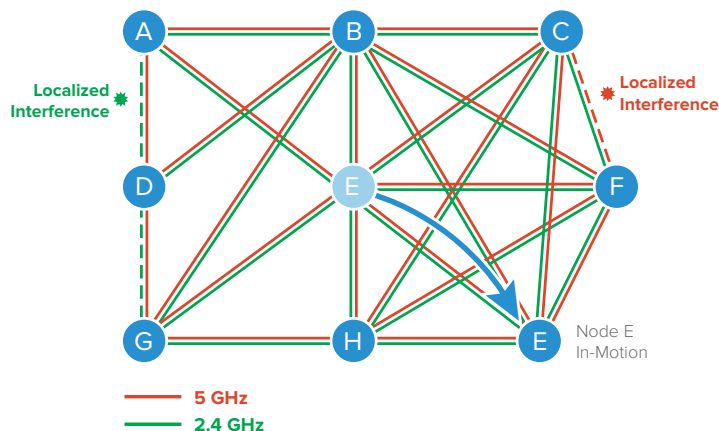

¹ U.S. Patent 8341289B2

Model	Description
ME4-2409R	ME4 with (1) 2.4 GHz, 2x2 MIMO, 300 Mbps and (1) 900 MHz, 65 Mbps transceivers.
ME4-2424S	ME4 with (2) 2.4 GHz, 2x2 MIMO, 300 Mbps transceivers.
ME4-2449R	ME4 with (1) 2.4 GHz, 2x2 MIMO, 300 Mbps and (1) 4.9 GHz, 2x2 MIMO, 300 Mbps transceivers.
ME4-2450R	ME4 with (1) 2.4 GHz, 2x2 MIMO, 300 Mbps and (1) 5 GHz, 2x2 MIMO, 300 Mbps transceivers.
ME4-4950R	ME4 with (1) 4.9 GHz, 2x2 MIMO, 300 Mbps and (1) 5 GHz, 2x2 MIMO, 300 Mbps transceivers.
ME4-5009R	ME4 with (1) 5 GHz, 2x2 MIMO, 300 Mbps and (1) 900 MHz, 65 Mbps transceivers.
ME4-5050S	ME4 with (2) 5 GHz, 2x2 MIMO, 300 Mbps transceivers.

- Custom radio configurations are available upon request. May include a mix of licensed, military or unlicensed frequencies.
- The 900 MHz, 65 Mbps transceiver utilizes one antenna port. The 2.4 GHz, 4.9 GHz and 5 GHz 300 Mbps transceivers utilize two antenna ports in 2x2 MIMO (multiple-input and multiple-output) configuration.
- For 2x2 MIMO capable transceivers, the Max. RF Transmit Power specification is for the combined power output of the two antenna ports.

Wireless	900 MHz	2.4 GHz	4.9 GHz	5 GHz
Antenna Connector	(1) Type N Female	(2) Type N Female	(2) Type N Female	(2) Type N Female
Frequency²	902 — 928 MHz	2.402 — 2.472 GHz	4940 — 4990 MHz	U-NII-1: 5150 — 5250 MHz U-NII-2A: 5250 — 5350 MHz U-NII-2C: 5470 — 5725 MHz U-NII-3: 5725 — 5850 MHz
Modulation	DSSS, CCK, OFDM	DSSS, CCK, OFDM	OFDM	OFDM
Max. Physical Layer Data Rate	65 Mbps (throughput varies)	300 Mbps (throughput varies)	300 Mbps (throughput varies)	300 Mbps (throughput varies)
Max. RF Transmit Power³	30 dBm ± 1 dB	29 dBm ± 2 dB	23 dBm ± 1.5 dB	28 dBm ± 2 dB
Receive Sensitivity	Varying between -96 dBm ±1 dB and -73 dBm ±2 dB			

² Channel, frequency and bandwidth options will vary based upon regional and local regulations.

³ RF transmit power is governed by local regulations and varies by frequency.

Network & Security

Network Functionality

VLAN and QoS support; Access Point; Bridge; Gateway; DHCP; NAT and Port Forwarding; Automatic Protocol Tunneling (APT).

Security

- Multiple cryptographic options, including NSA Suite B algorithms (implementation not certified). For information on models with full Suite B certification, contact Rajant or your authorized Rajant partner.
- Separately configurable data and MAC address *encryption* via AES256-GCM, AES192-GCM, AES128-GCM, AES256-CTR, AES192-CTR, AES128-CTR, XSalsa20, XSalsa20/12, and XSalsa20/8.
- Configurable per-hop, per-packet *authentication* between BreadCrums via AES256-GMAC, AES192-GMAC, AES128-GMAC, HMAC-SHA512, HMAC-SHA384, HMAC-SHA256, HMAC-SHA224, and HMAC-SHA1.
- Supports IEEE 802.11i: AES-CCMP and TKIP encryption, WPA-Personal/Enterprise, WPA2-Personal/Enterprise, 802.1x; 64/128-bit WEP; Access Control Lists; Compatible with Layer-2 and Layer-3 client/server and peer-to-peer security solutions; Compatible with Harris SecNet 54[®] encryption.

Power

Input Voltage 8 — 48 VDC

Power Consumption⁴ 5.5 W (average, idle); 19 W (maximum, peak) @ 24 V

⁴ Power consumption depends on transceiver configuration.

Input / Output

Ethernet	(1) 10/100/1000 Mbps and (1) 10/100 Mbps, IEEE 802.3, RJ-45, auto MDI/MDIX
USB	Built-in USB port for firmware upgrades, and for GPS device add-on
LED	Status LED
Switch 1	LED Configuration / Zeroize Keys and Restore Factory Defaults Switch
Switch 2	Power On/Off

Physical

Dimensions	189 mm x 95 mm x 51 mm (7.46" x 3.75" x 2.00")
Weight	1162 g ± 100 g (2 lbs 9 oz ± 3.5 oz) (weight depends on transceiver configuration)
Temperature	<p>Models with 900 MHz or 2.4 GHz radios, NO heater: Startup: 0 °C to 80 °C (32 °F to 176 °F) Operating: -20 °C to 80 °C (-4 °F to 176 °F) Storage: -40 °C to 80 °C (-40 °F to 176 °F)</p> <p>Models with 900 MHz or 2.4 GHz radios, with heater option: Startup: -40 °C to 80 °C (-40 °F to 176 °F) Operating: -40 °C to 80 °C (-40 °F to 176 °F) Storage: -40 °C to 80 °C (-40 °F to 176 °F)</p> <p>All Other Models: Startup: -40 °C to 80 °C (-40 °F to 176 °F) Operating: -40 °C to 80 °C (-40 °F to 176 °F) Storage: -40 °C to 80 °C (-40 °F to 176 °F)</p>

Humidity 95% (non-condensing)

Enclosure Designed for IP67 (6: Dust-tight, 7: Waterproof)

Certification	<p>FCC Part 15 (USA): ME4-2450R, ME4-4950R, ME4-5050S, ME4-2409R, ME4-2424S, ME4-2449R, ME4-5009R</p> <p>FCC Part 90Y (USA): ME4-4950R, ME4-2449R</p> <p>ICES-003 and RSS-210 (Canada): ME4-2450R (heated only, unheated pending), ME4-4950R, ME4-5050S, ME4-2409R, ME4-2424S, ME4-2449R, ME4-5009R</p> <p>RSS-111 (Canada): ME4-4950R, ME4-2449R</p> <p>CE mark (European Economic Area, Switzerland and Turkey): ME4-2450R, ME4-5050S</p> <p>AS/NZS 4268 (Australia and New Zealand): ME4-2450R, ME4-5050S</p>	<p>ICASA (South Africa): ME4-2450R, ME4-5050S</p> <p>ANATEL (Brazil): ME4-2450R, ME4-5050S</p> <p>SUBTEL (Chile): ME4-2450R, ME4-5050S</p> <p>ARTEC (Madagascar): ME4-2450R</p> <p>CRC (Columbia): ME4-2450R</p> <p>IFT/NOM (Mexico): ME4-2450R</p> <p>Peru: ME4-2450R</p> <p>TRA (United Arab Emirates): ME4-2450R</p> <p>SMA (Jamaica): ME4-5050S</p>
----------------------	--	---

Warranty 1 Year